

MOTOPOMPA M 1000

12,5 CP DIESEL

*Debit 1000 l/min
Consum 1 l/h*

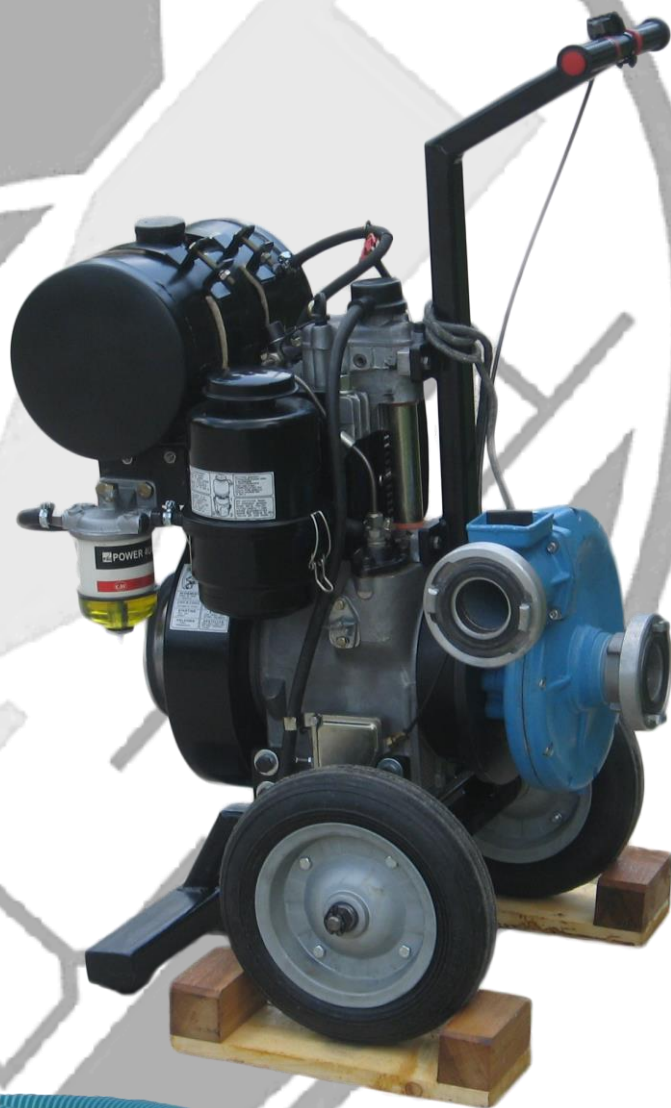

Motor:

Diesel in 4 timpi	3LD450
Numar cilindri.....	1
Alezaj.....	85 mm
Cursa.....	80 mm
Capacitate cilindrica.....	454 cmc
Raport de compresie.....	17,5 : 1
Turatie.....	3000 rot/min
Moment de torsiune.....	28,5 Nm/1700 rot/min
Consum specific motorina	1,7 litri/h
Consum specific ulei	0,007 Kg/h
Greutate „uscata”.....	57Kg
Putere la 3000 rot/min	
N DIN 70020-80/1269/CEE ISO 1585.....	7,5 Kw
NB DIN 6271 – ISO 3046 – 1IFN.....	6,6 Kw
NA DIN 6271 – ISO 3046 – 1ICXN.....	6 KW
Greutate totala ans. Motopompa.....	94 Kg

Executie standard :

Pornire manuala cu sfoara	
Filtru de ulei si de aer	
Amortizor de zgomot	
Rezervor de motorina..	10 litri
Control manual al turatiei	
Cadru pe roti	
Roti pneumatice.....	Ø 260 / Ø 20
Cupla absorbtie	STORZ, marimea B (3”)
Cupla refulare.....	STORZ, marimea B (3”)
Manual de utilizare si intretinere	
Lista pieselor de schimb	

Optional

Furtun absorbtie armat Ø 76.....	10m
Furtun refulare 3” complet.....	20m
Cupla rapida STORZ , 3”.....	1 buc.
Sorb 3” cu clapet.....	1 buc.

H m H₂O

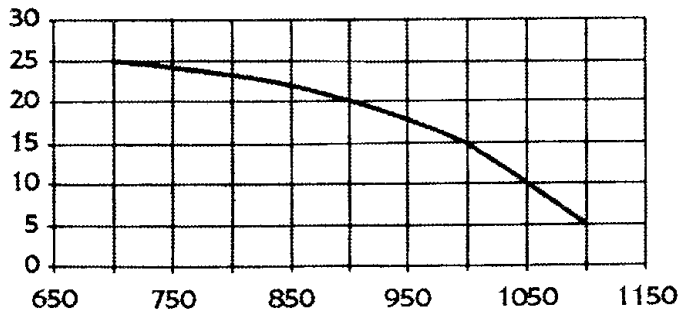

Q l/min

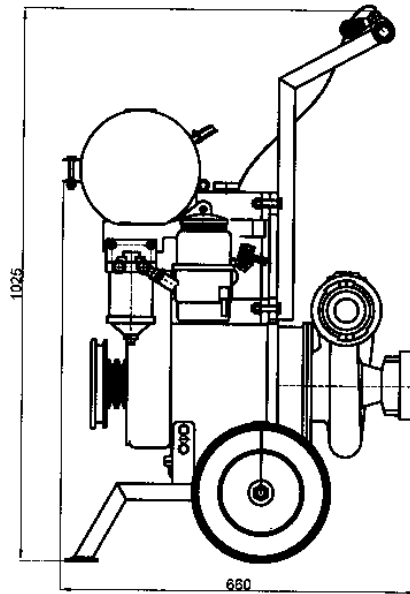
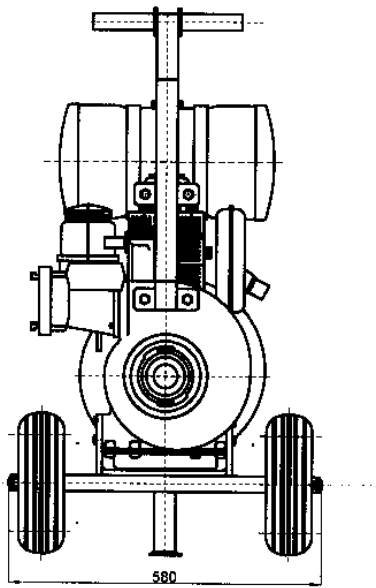

Q l/min

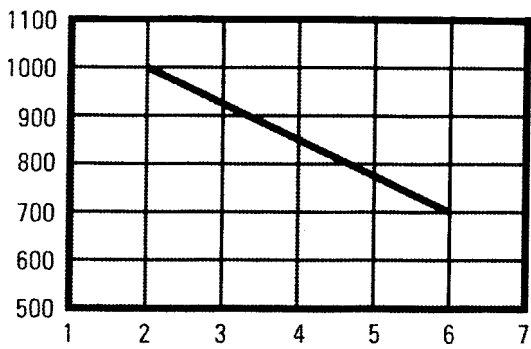

A m H₂O

